

Transformador de aterramento ZIG-ZAG IP 00 – Rede 13,8kV

Transformador de Aterramento Zig-Zag (Rede 13,8 kV) 10 s IP00

Potência Aterramento (kVA)	Xaterramento (Ω)	Ifase Regime (A)	Ineutro Regime (A)	Ifase de curta duração (10s) (A)	Ineutro de curta duração (10s) (A)	A máx (mm)	B máx (mm)	C máx (mm)	Massa (kg)	Modelo	Item Pólux
50	171,4	2,1	6,3	42	126	1150	1050	650	350	A	Sob consulta
100	85,7	4,2	12,6	84	251	1200	1150	700	550	A	Sob consulta
200	42,8	8,4	25,1	167	502	1300	1250	700	650	A	Sob consulta
300	28,6	12,6	37,7	251	753	1300	1300	750	780	A	Sob consulta
400	23,8	16,7	50,2	335	1004	1450	1400	800	1000	A	Sob consulta
500	19	20,9	62,8	418	1255	1550	1400	800	1120	A	Sob consulta

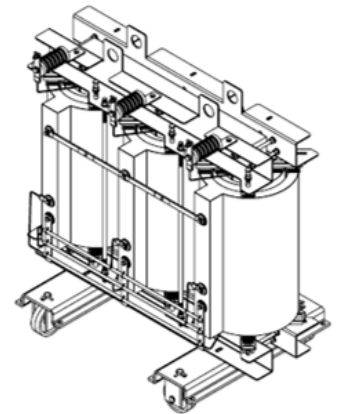
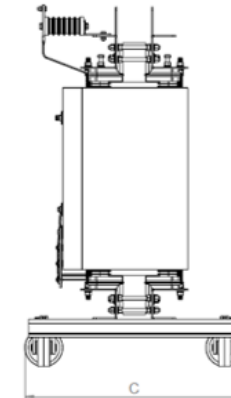
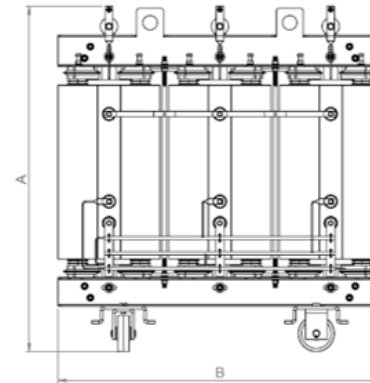
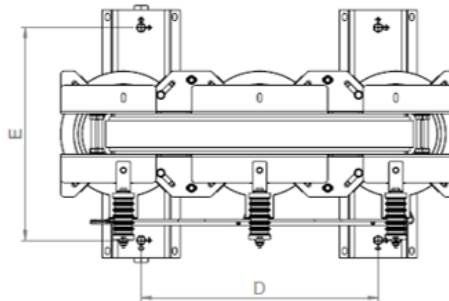

Transformador de aterramento ZIG-ZAG IP 54 – Rede 13,8kV

Transformador de Aterramento Zig-Zag (Rede 13,8 kV) 10 s IP54

Potência Aterramento (kVA)	Xaterramento (Ω)	Ifase Regime (A)	Ineutro Regime (A)	Ifase de curta duração (10s) (A)	Ineutro de curta duração (10s) (A)	A máx (mm)	B máx (mm)	C máx (mm)	Massa (kg)	Modelo	Item Pólux
50	171,4	2,1	6,3	42	126	1180	1480	1080	550	B-IP54	Sob consulta
100	85,7	4,2	12,6	84	251	1180	1480	1080	650	B-IP54	Sob consulta
200	42,8	8,4	25,1	167	502	1300	1600	1050	750	B-IP54	Sob consulta
300	28,6	12,6	37,7	251	753	1350	1800	1100	900	C-IP54	Sob consulta
400	23,8	16,7	50,2	335	1004	1800	1800	1250	1150	C-IP54	Sob consulta
500	19	20,9	62,8	418	1255	1800	1800	1250	1300	C-IP54	Sob consulta

